



Automatic Inventory Storage / Retrieval System

A Value Engineering Study for
Tekdata



Summary

- Tekdata is a provider of engineering and manufacturing services dealing primarily with sheet metal
 - Frequent retrieval of sheet metal in production
 - A automated retrieval system could increase storage space and expedite the process of retrieving and storing raw materials.

Outline

- **Samer Abughannam**
Introduction, Information Gathering, Functional Analysis
- **Antonio Pagano**
Racking System and Skid
- **Mathieu Poitras**
Horizontal Movement
- **Arman Oduncuoglu**
Vertical Movement and Inventory
- **Jean-Simon Lavallée**
Manipulator
- **Antonio Pagano**
Return on Investment, Net Present Value, Conclusion

Planning

- Primary goal in planning the study was to follow Value Engineering Job Plan:
 - Information Gathering
 - Functional Analysis
 - Creativity Sessions
 - Evaluation of Ideas and Proposals
 - Recommendations
 - Conclusion

Information Gathering



Current Storage System

Information Gathering

- Visit to Tekdata's production facility

Constraint	Value
Support weight of sheets	7000lbs
Allow to fit different size sheets	Width: 3' or 4' Length: 8', 10', 12' Thickness: varying
Take advantage of the entire height of the facility	24'
Be completely automated	
Have a standardized skid/shelving system	
Comply with CSST health and safety rules	
<u>Two rows of racking, serviced by one manipulator</u>	

Functional Analysis

- Need expressed in terms of functions and not solutions
- Three types
 - Basic or Service function
 - Secondary or technical support
 - Constraint
- Functions described with an active verb + measurable noun. E.g.:
Store sheet metal, ensure safety, etc

Functional Analysis

- Intuitive Research - Environmental Analysis

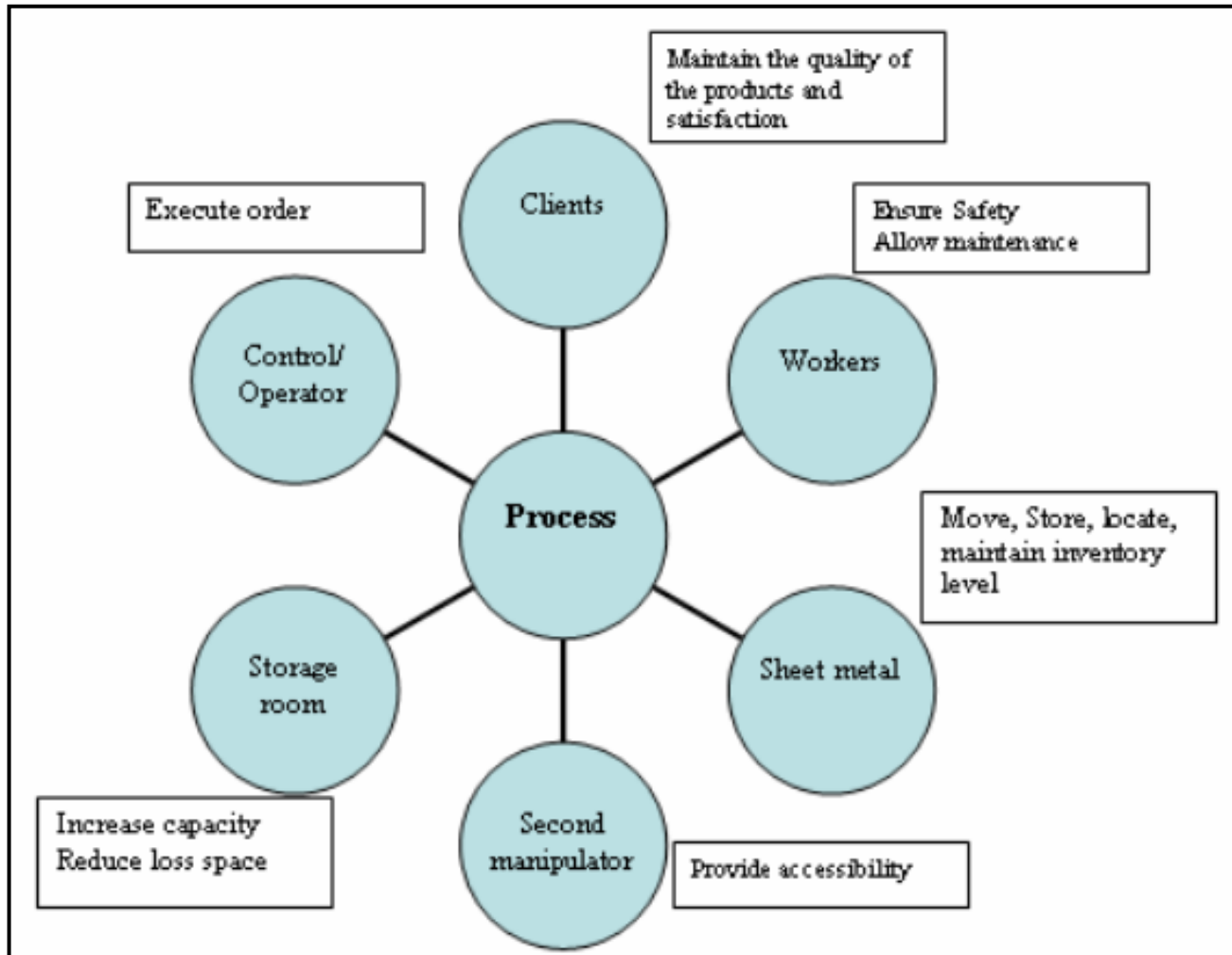

Functional Analysis

■ Sequential Analysis

Sequence of Activities	Function Verb	Function noun
Control system	Send	order
System	Receive	order
System	Move	table
Table	Locate	skid
Manipulator	Retrieve	skid
System	Return	table to original position
Manipulator 2	remove/add	metal sheets
System	Move	to same skid location
Manipulator	Store	skid
Table returns	Return	to original position

- Automate storage and retrieval of sheet metal in a **safe, reliable, and efficient** manner
- Increase **capacity** of storage room
- Decrease required **labour and time**

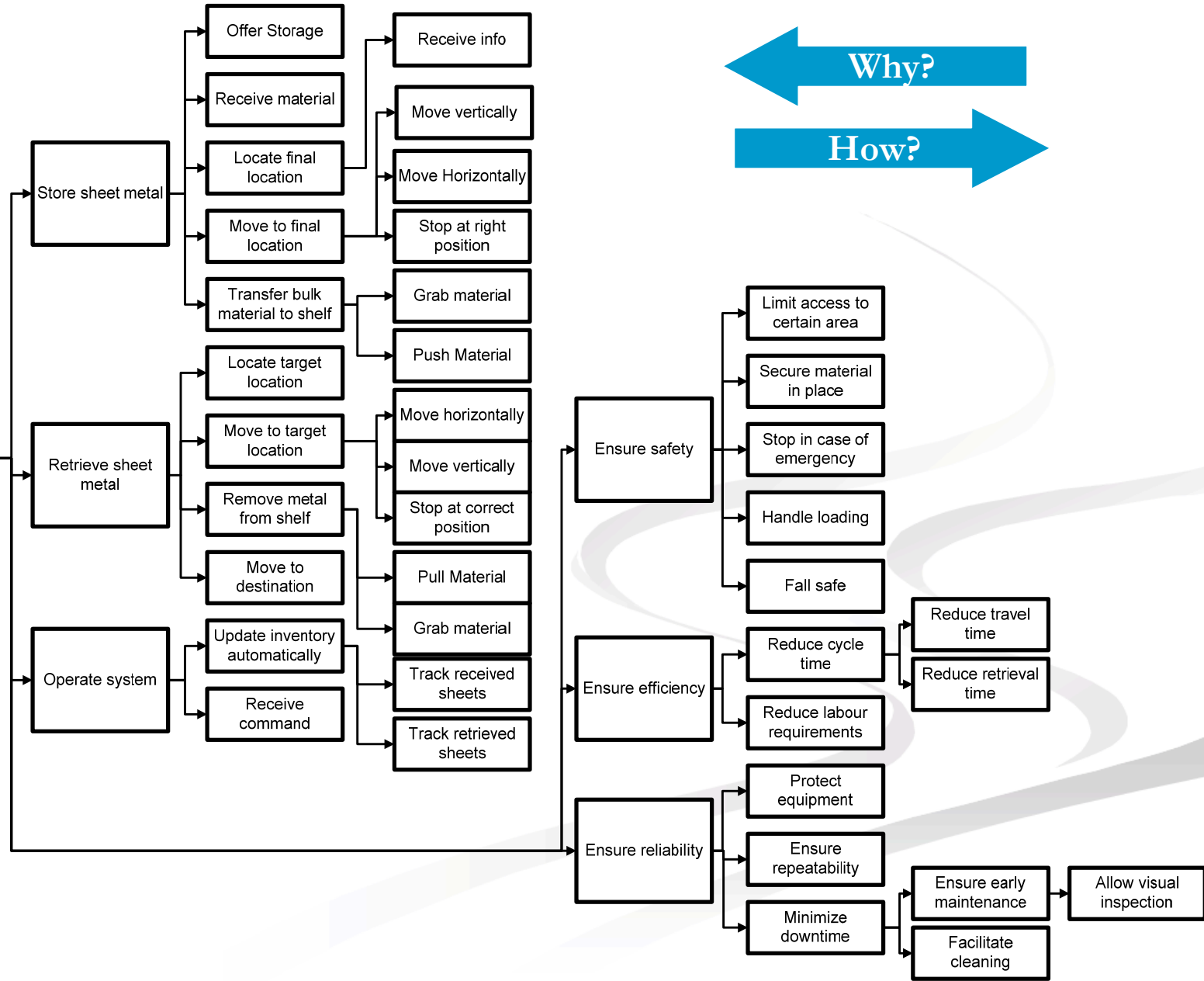

← Why?

→ How?

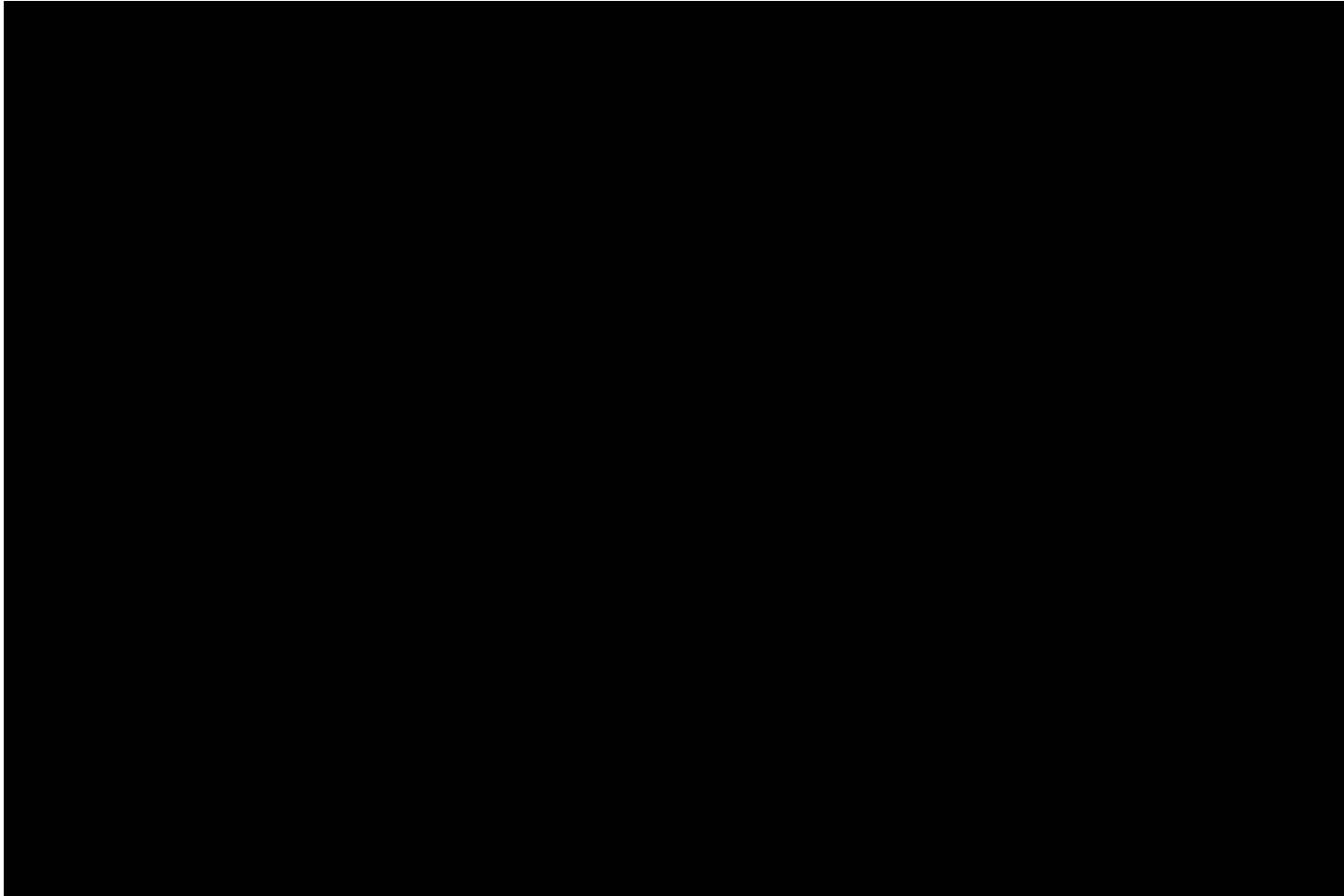

Creativity Sessions

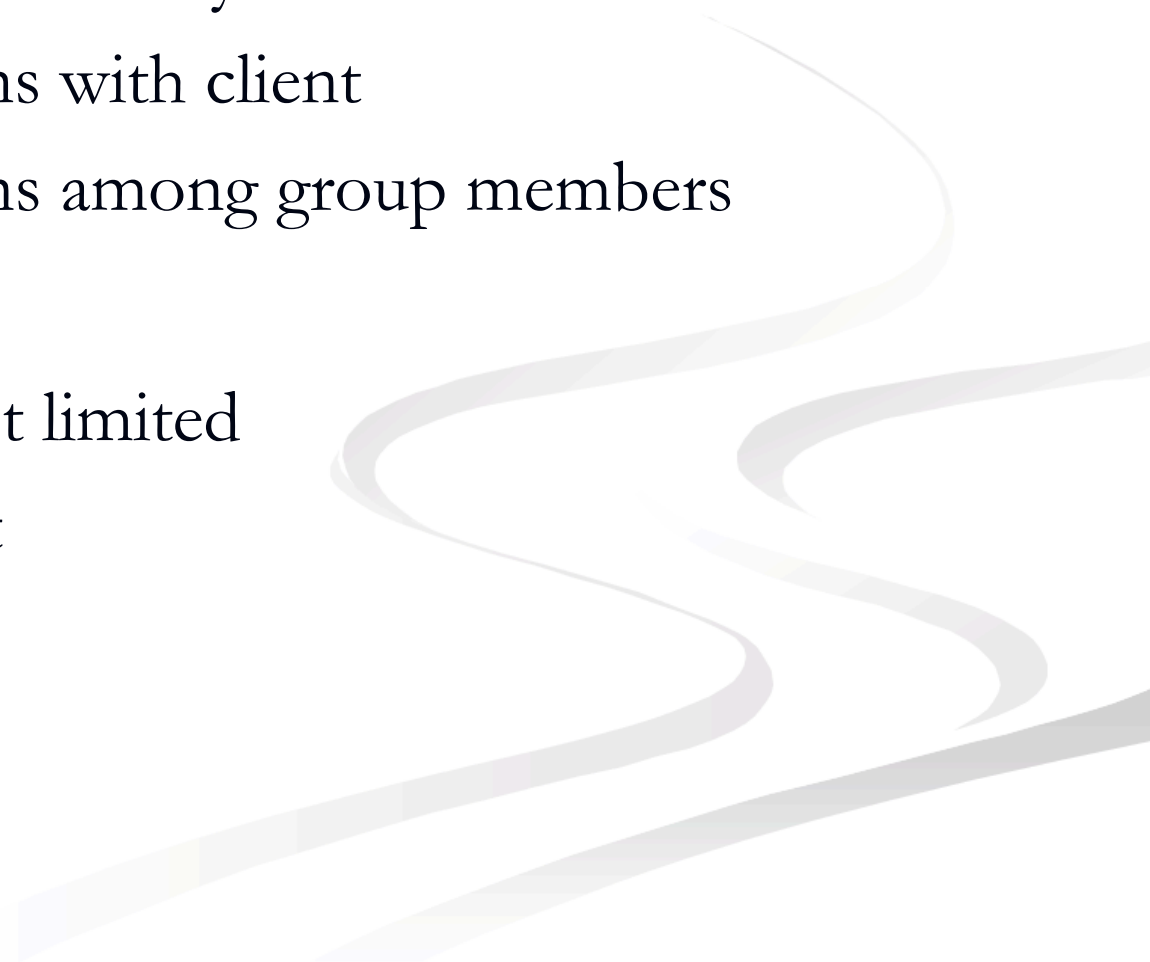
- Implemented in two ways:
 - Creativity Sessions with client
 - Creativity Sessions among group members
 - Brainstorming
 - Creativity was not limited
 - Support all effort
- 

Creativity Sessions: Outcome

- Creativity Session Outcomes:
 - Concepts generated to meet specific functions
 - Concepts from each of the steps were combined to form full model concepts
 - Attention to compatibility

Racking System and Skid

- Racking System: Derived from current pallet storage systems equipped with C-Channels

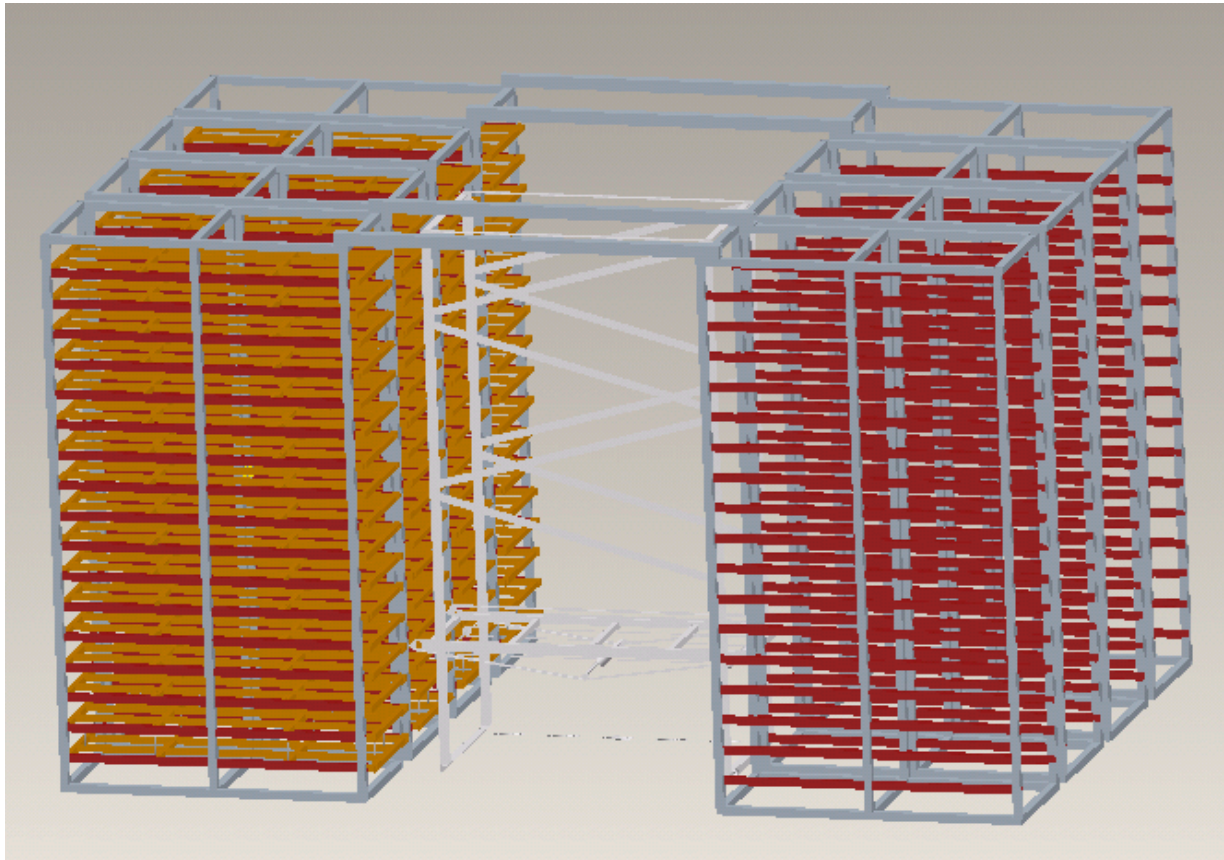

Racking System and Skid

- Skid Design: Manufacturability, Reliability, Packaging

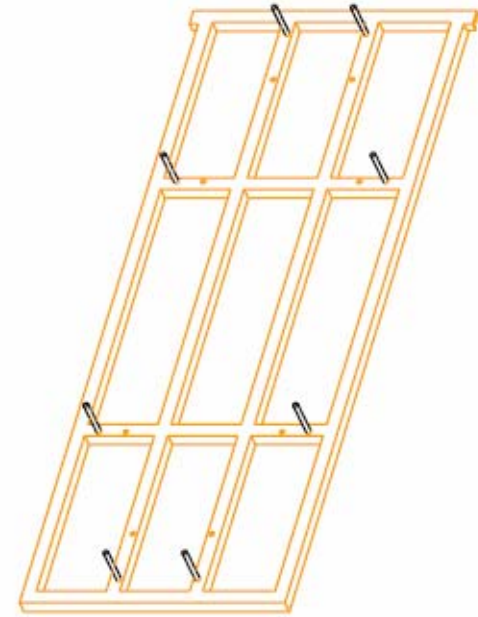
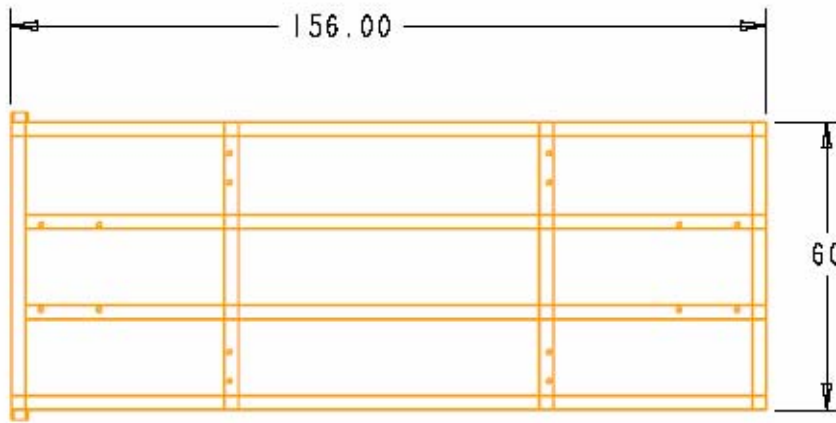

Evaluation Criteria

- Value of concepts is compared based on the following weighted criteria such as:
 - Simplicity
 - Reliability
 - Accuracy
 - Safety
 - Low Maintenance
 - Manufacturability
 - Time saving

Move Horizontally

- Wheels on the ground and electric drive



Advantages:

- Simple
- Cheap
- Use of ground

- Rack and pinion System

Advantages:

- Precision

Disadvantages:

- Expensive
- Complex Manufacturing

Cost/Merit Comparison

Horizontal movement			
Criteria	Weight	Concept 1	Concept 2
		<i>Shaft/motor, wheel on ground</i>	<i>Rack and pinion system</i>
Simplicity	8	10	7
Reliability	8	9	9
Accuracy	10	7	8
Safety	9	9	9
Low Maintenance	7	9	8
Time Saving	9	9	8
Manufacturability	10	10	7
Total		547	487
Cost		\$ 1,700	\$ 2,775

Cost/Merit Comparison

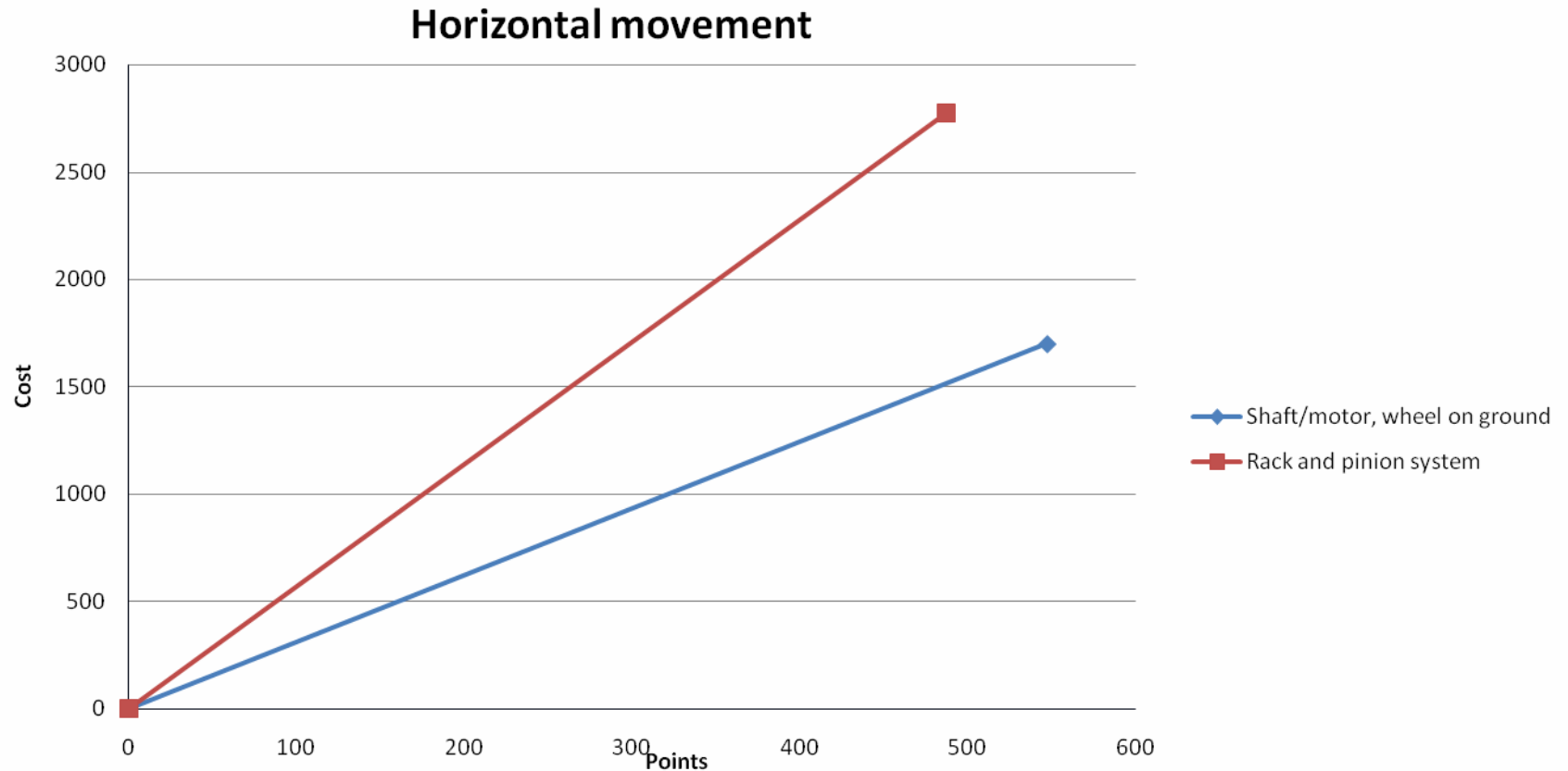

Move Vertically

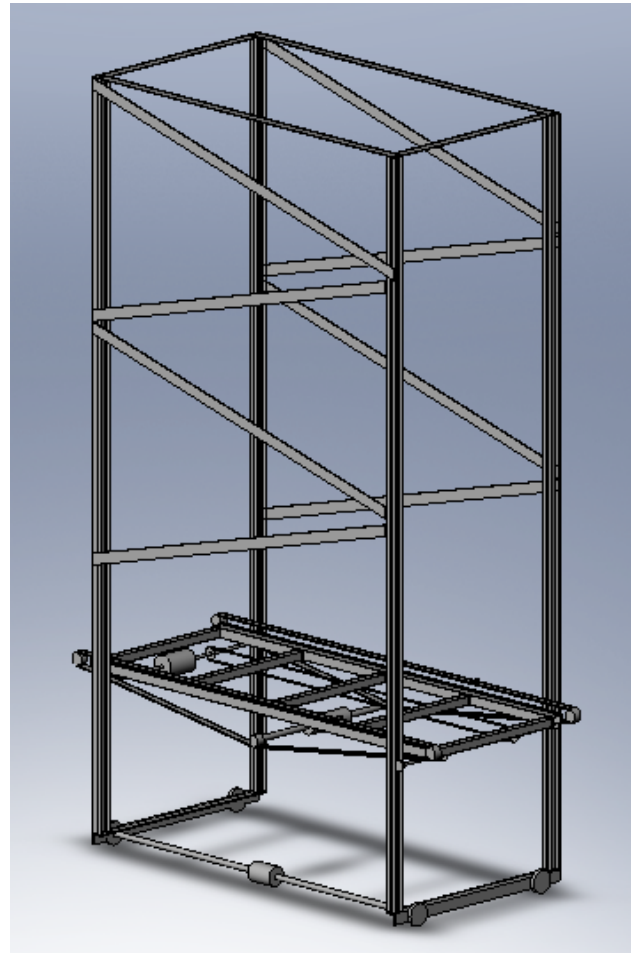

Move Vertically

- Rack and pinion system

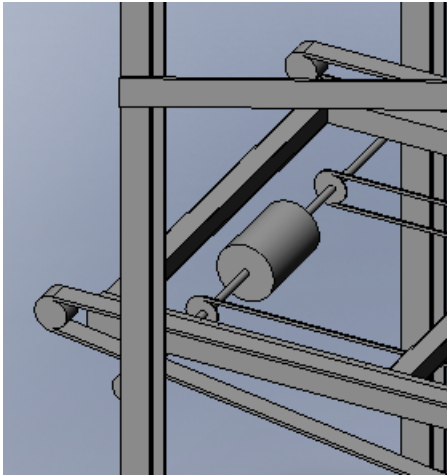

Advantages:

- Low-maintenance
- Accuracy
- Reliab. / Repeat.

Disadvantages:

- Production cost

- Hoist and cables

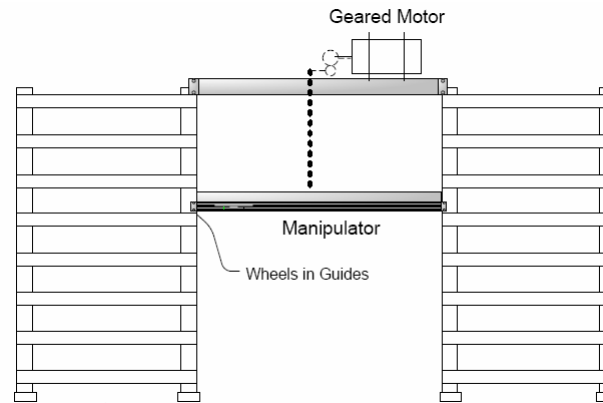

Advantages:

- Easy to apply
- Conventional

Disadvantages:

- Slow
- Maintenance
- Accuracy

- Chain and sprocket system

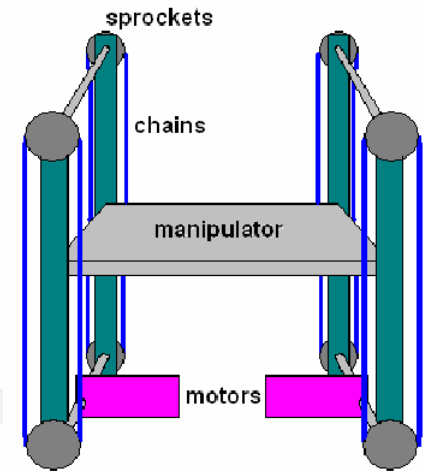

Advantages:

- Stationary motors

Disadvantages:

- Stretching chain
- Maintenance
- Accuracy

Cost/Merit Comparison

Vertical Movement				
Criteria	Weight	Concept 1 <i>Rack and Pinion</i>	Concept 2 <i>Hoist</i>	Concept 3 <i>Chain system</i>
Simplicity	8	9	7	6
Reliability	8	10	7	7
Accuracy	10	9	7	6
Safety	9	9	9	9
Low Maintenance	7	10	7	8
Time Saving	9	8	6	7
Manufacturability	10	9	5	8
Total		555	416	444
Cost		\$ 16,585	\$ 13,600	\$ 15,200

Cost/Merit Comparison

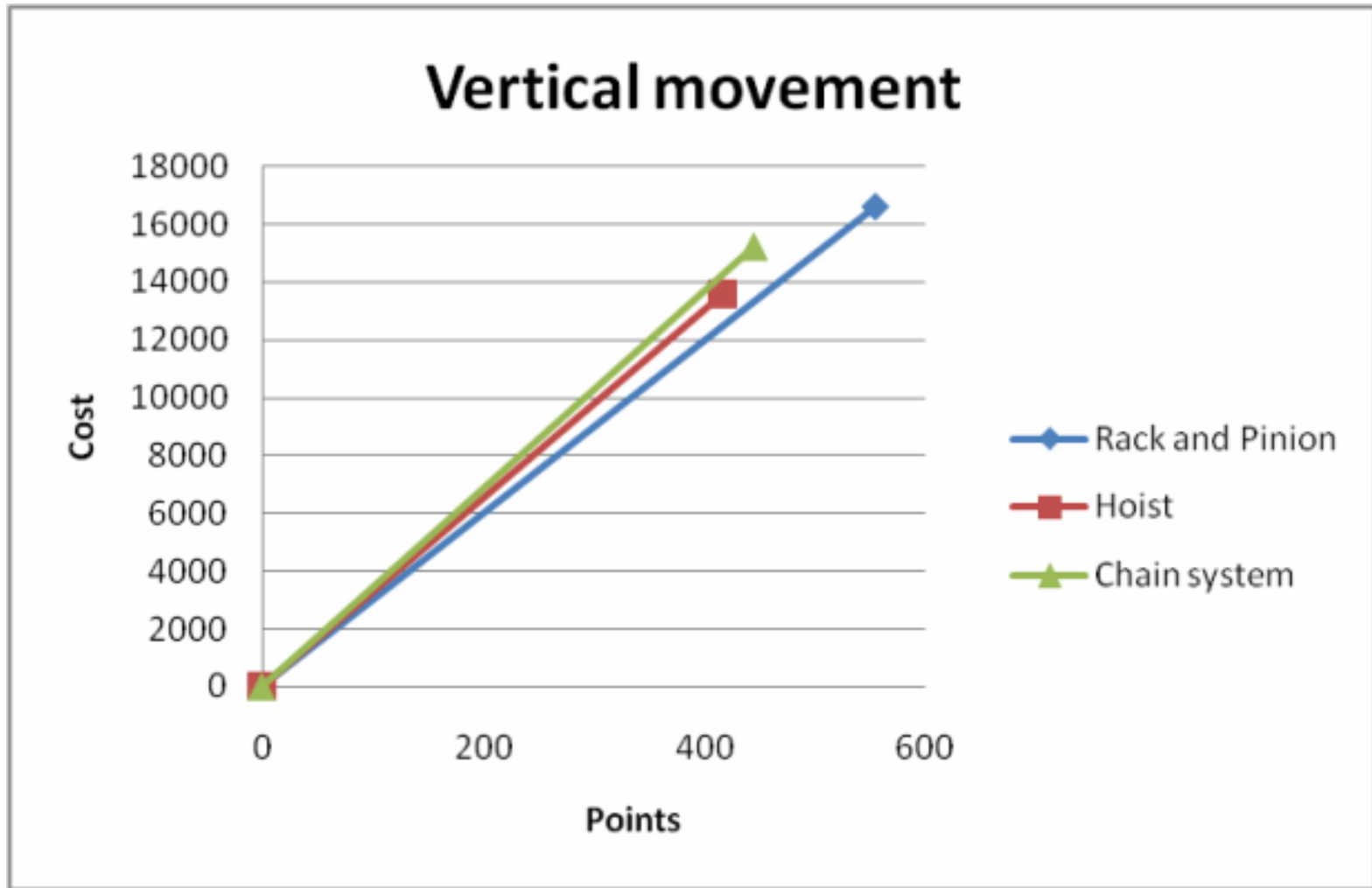

Locate material/Inventory Control

■ Industrial Scanner



Advantages:

- Digital position information
- Operator independent inventory update
- Cheap \$400.

Disadvantages:

- Maintaining barcodes

■ Proximity Sensor

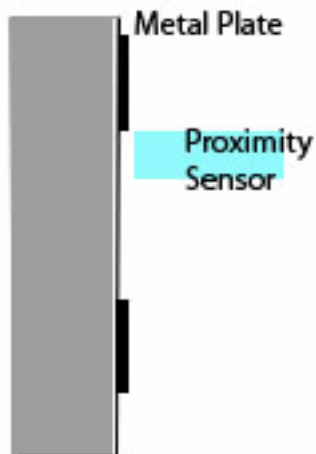

Advantages

- Very cheap
- Simple

Disadvantages

- Analog output
- Operator dependency



Parallel
Install

Retrieve material

Functions: grab and pull/push material

Hydraulic gripper

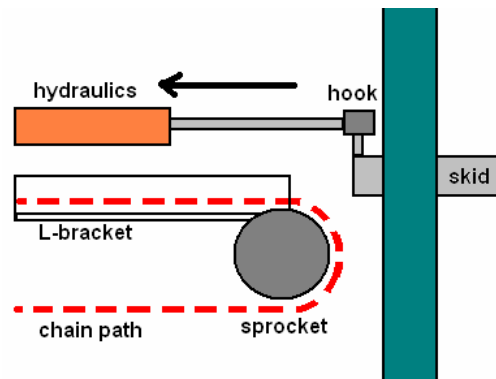

Advantages:

- Fast
- Powerful

Disadvantages:

- 2 energy sources
- Complex

Translating table

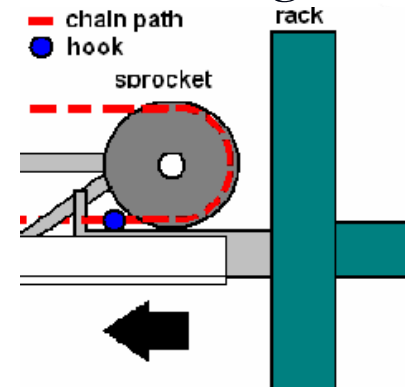

Advantages:

- Fast

Disadvantages:

- 2 movements
- Expensive
- Complex

Retrieve material

Functions: grab and pull/push material

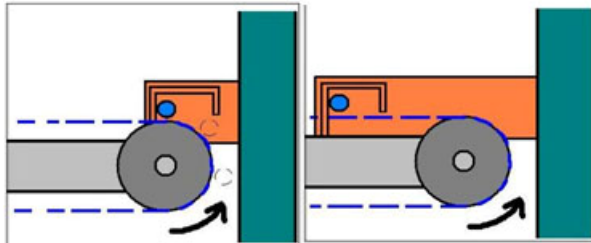

- Chain and hook system

Advantages:

- 1 Motion
- Simple

Disadvantages:

- Slower

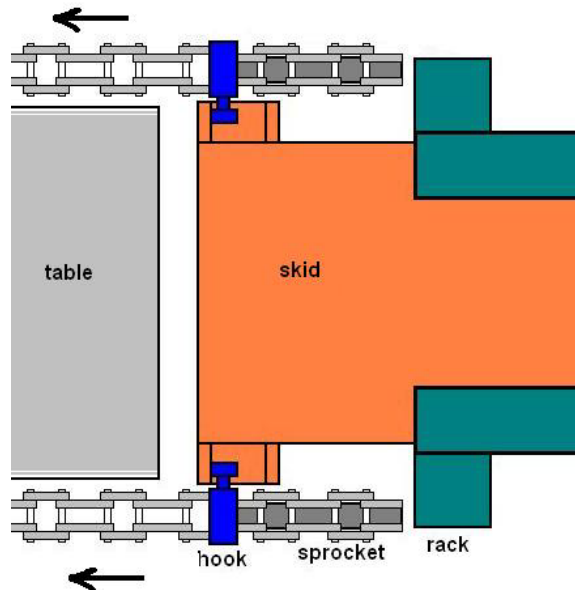

Cost/Merit Comparison

Store and retrieve material				
Criteria	Weight	Concept 1 <i>Chain system</i>	Concept 2 <i>Hydraulic gripper</i>	Concept 3 <i>Translating table</i>
Simplicity	8	10	7	6
Reliability	8	9	9	9
Accuracy	10	10	9	9
Safety	9	9	9	9
Low Maintenance	7	8	8	8
Time Saving	9	8	10	10
Manufacturability	10	10	7	9
Total		561	515	527
Cost		\$ 1,460	\$ 2,050	\$ 4,010

Cost/Merit Comparison

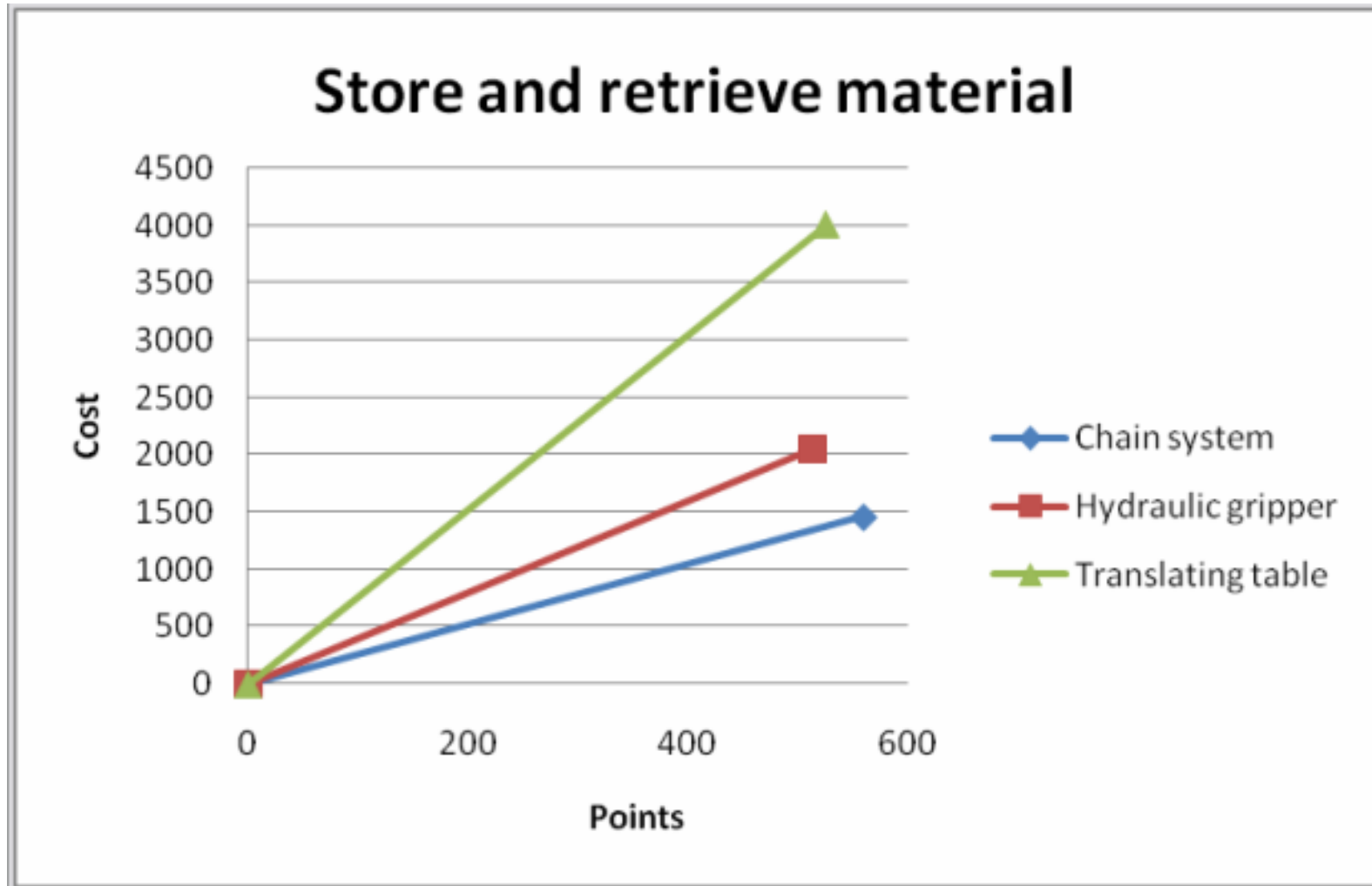

Net Present Value / ROI

- A net present value of \$30,000
- Assumptions:
 - Yearly time savings: 470 hours
 - Growth Rate of 3% per annum
 - Hourly rate of man power: \$24.00
 - Total Cost of \$75,000
 - Cost of Capital : 10%
 - CCA Depreciation Rate : 30%
 - Tax Rate : 34%
 - 250 days/year of operation
 - Assumed 50% improval in storage/retrieval times
- ROI: 32% over 10 years (Based on NPV)
- Payback: 6.5 years

Cash Flow Projections

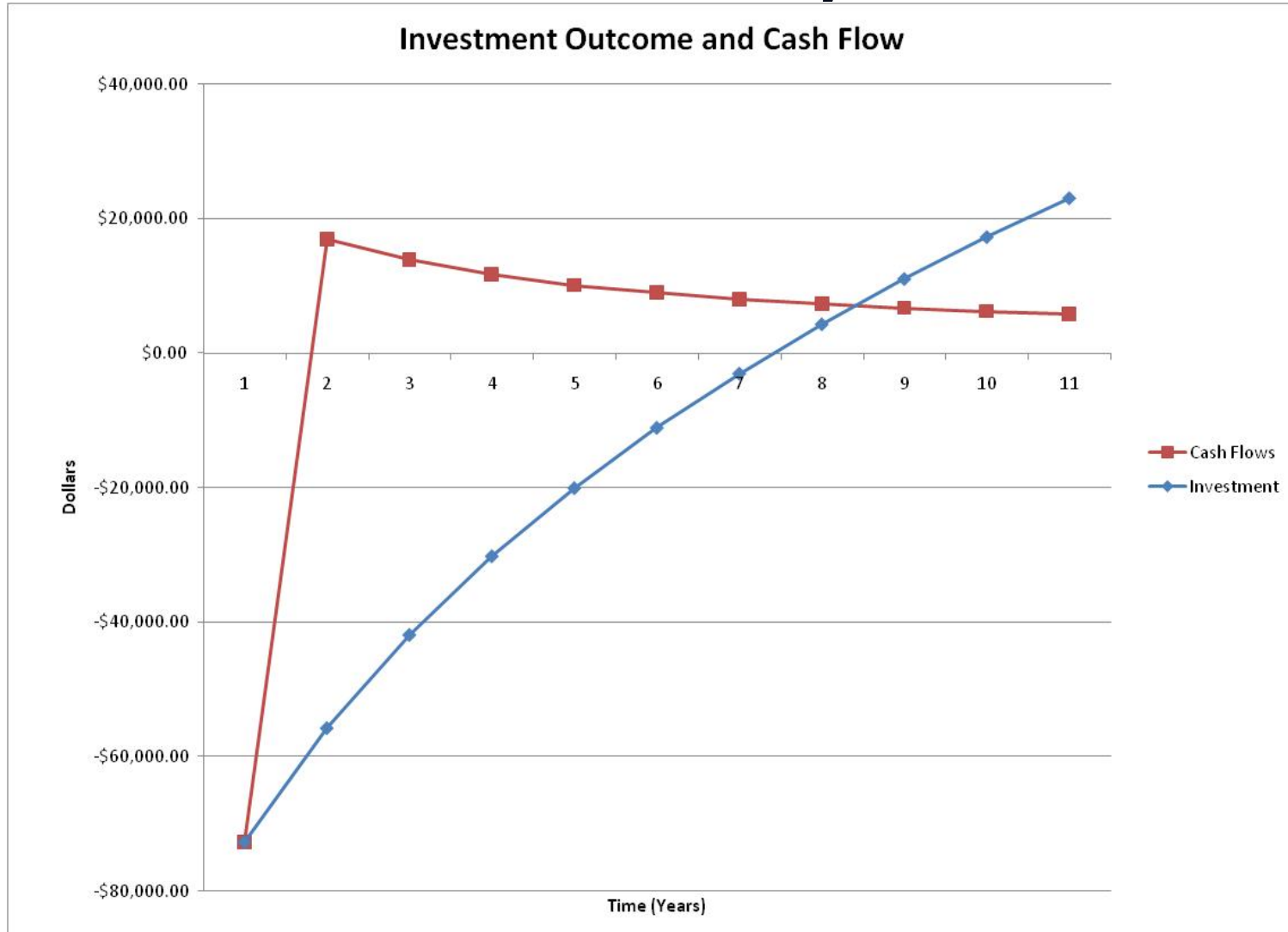

Conclusion

- Value Engineering Job Plan resulted in a concise design that meets the customers needs while minimizing costs.
- The proposed design should be implemented by Tekdata to minimize future costs and overhead.
 - Total projected cost of \$75,000 is more than offset by the present value of saving the device will give.