

Public Works Canada

Analysis of Workplace Requirements

Montreal 2018



1. CONTEXT AND THEORY

- Public Services and Procurement Canada (previously PWGSC) Quebec region is relocating its office.
- PSPC management is aware of a new trend in office planning. Activity Based Workplace (ABW) has caught its attention and is adopted as the driving principle for the design of the new office spaces.
- Project management calls for the services of a firm specializing in functional and technical programming to help define project requirements.
- Project must comply with the principles set out in the national standard “Workplace 2.0”.



1. CONTEXT AND THEORY

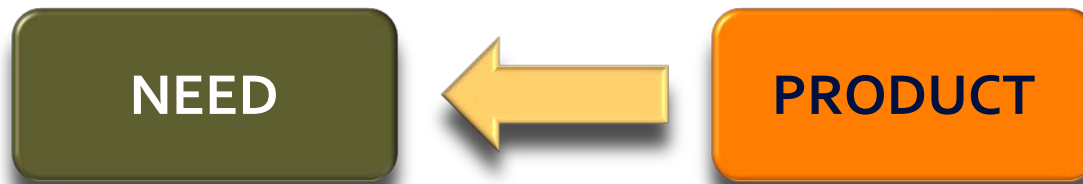

CONSUMER APPROACH

If the product is what it is then the need has been considered

TRADITIONAL CONSTRUCTION APPROACH

The architect knows what to do



1. CONTEXT AND THEORY

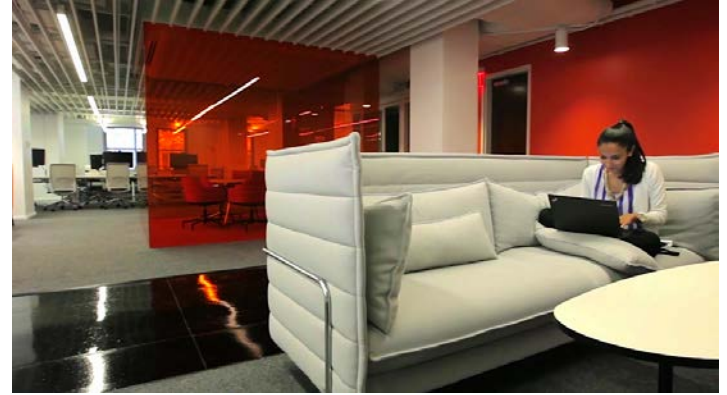



1. CONTEXT AND THEORY

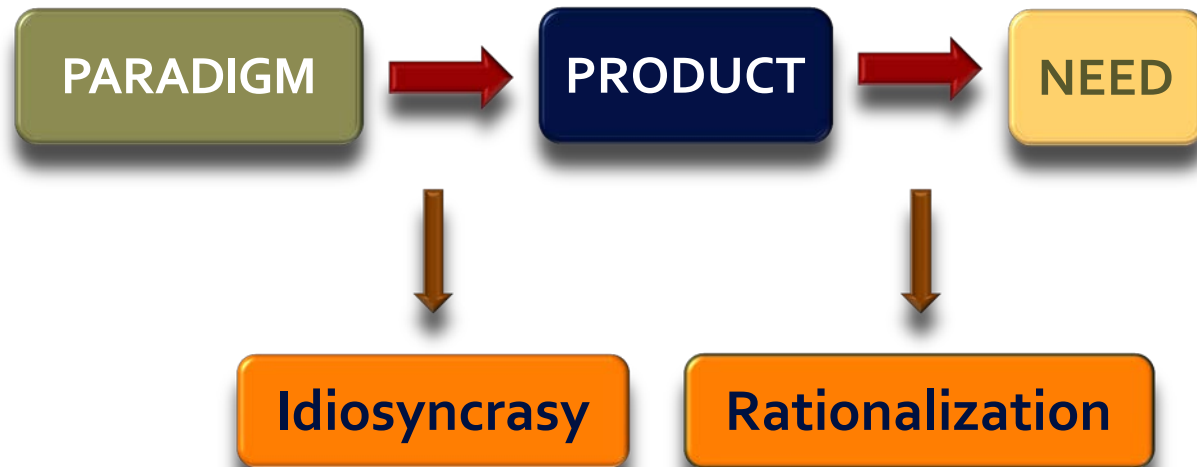



1. CONTEXT AND THEORY

NEED SHAPES THE PRODUCT



1. CONTEXT AND THEORY



OR



VALUE ?



1. CONTEXT AND THEORY



OR



NEED SATISFACTION / COST



1. CONTEXT AND THEORY





1. CONTEXT AND THEORY

- Imposed product
- Uncertainty at mid management level
- Incomprehension form the staff
- Arbitrary constraint
- Cost efficiency inadequately defined



1. CONTEXT AND THEORY

Functional Analysis



2. ACTIVITY BASE WORKPLACE (ABW)

**ORGANIZATIONAL
PRODUCT**



2. ACTIVITY BASE WORKPLACE (ABW)

- Time and place independence
- Empowerment
- Collaborative
- Open & flexible workplaces
- Technological / Connectivity
- Paper light



3. GENERAL SEQUENCE

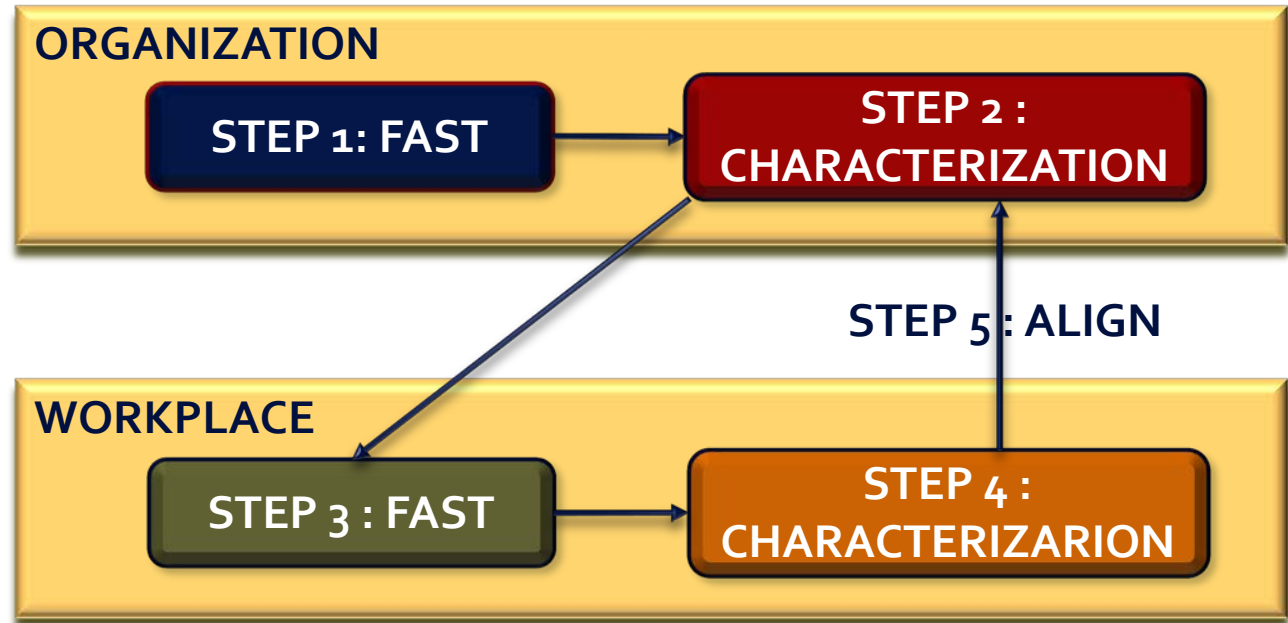



3. GENERAL SEQUENCE

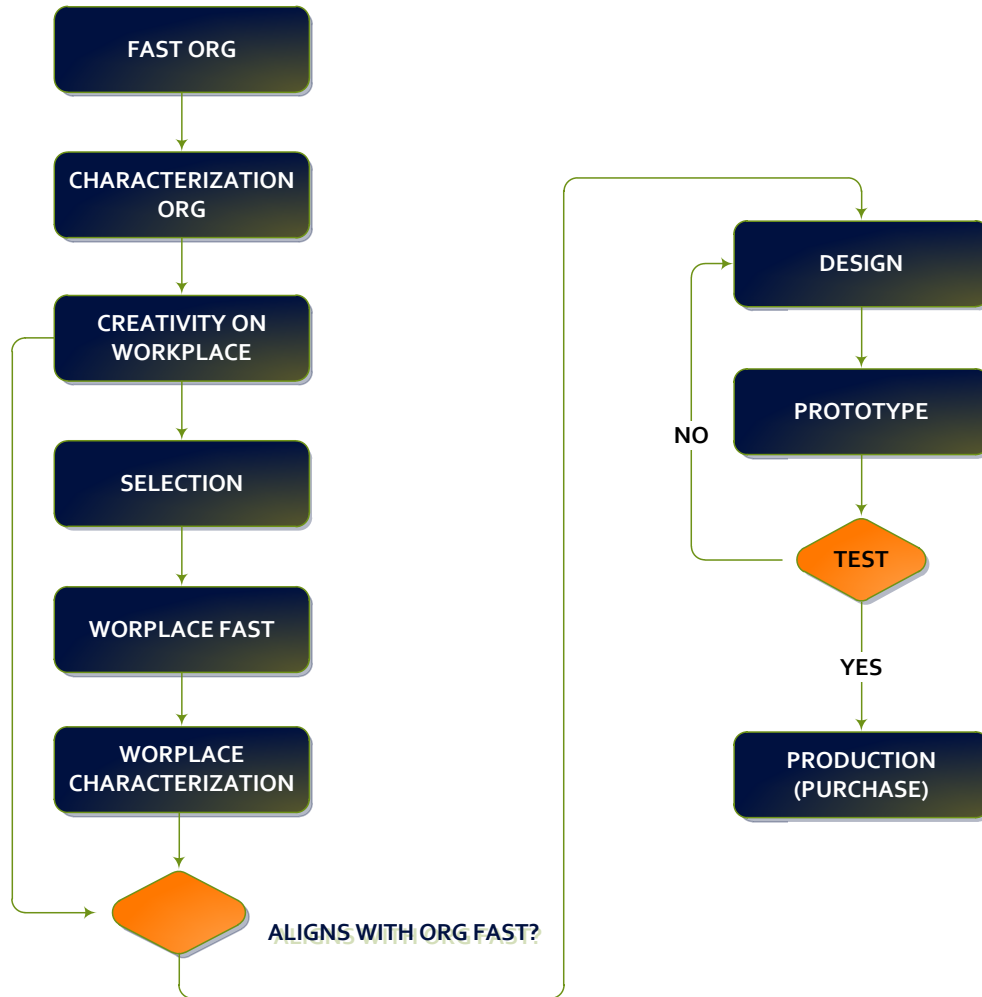



4. WORKING WITH GROUPS

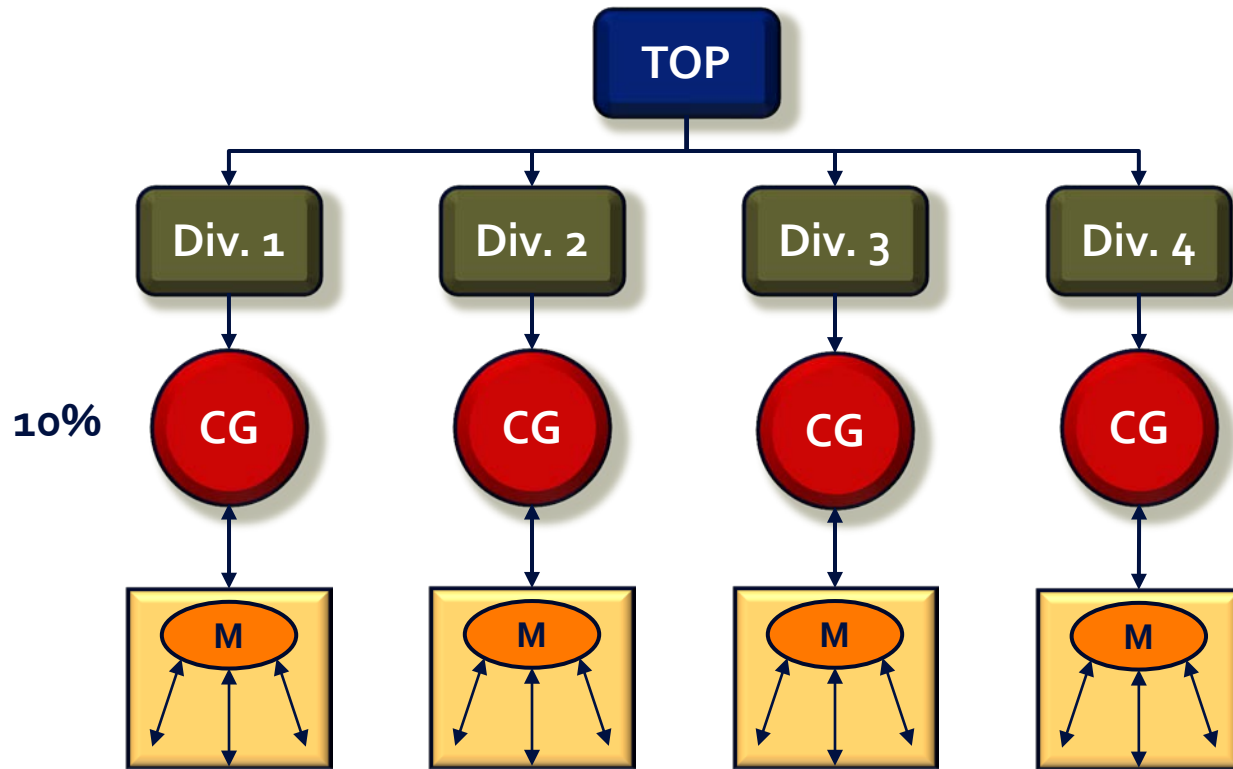



4. WORKING WITH GROUPS

	CLASS 1	CLASS 2	CLASS 3	CLASS 4	CLASS 5
CG ₁	●		●	●	●
CG ₂		●	●	●	
CG ₃	●	●	●	●	●
CG ₄	●	●	●		
CG ₅		●	●		
CG ₆	●		●		●



4. WORKING WITH GROUPS

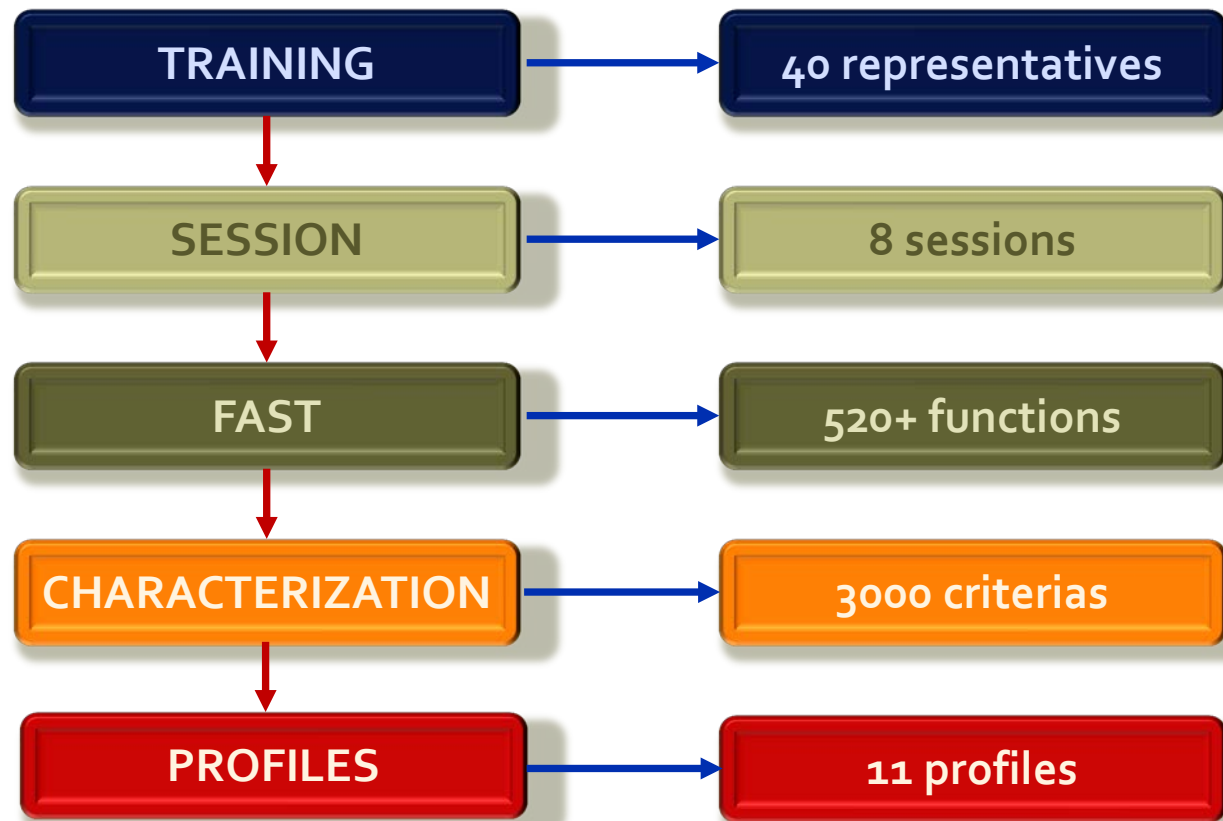



5. DELIVERABLES: FAST

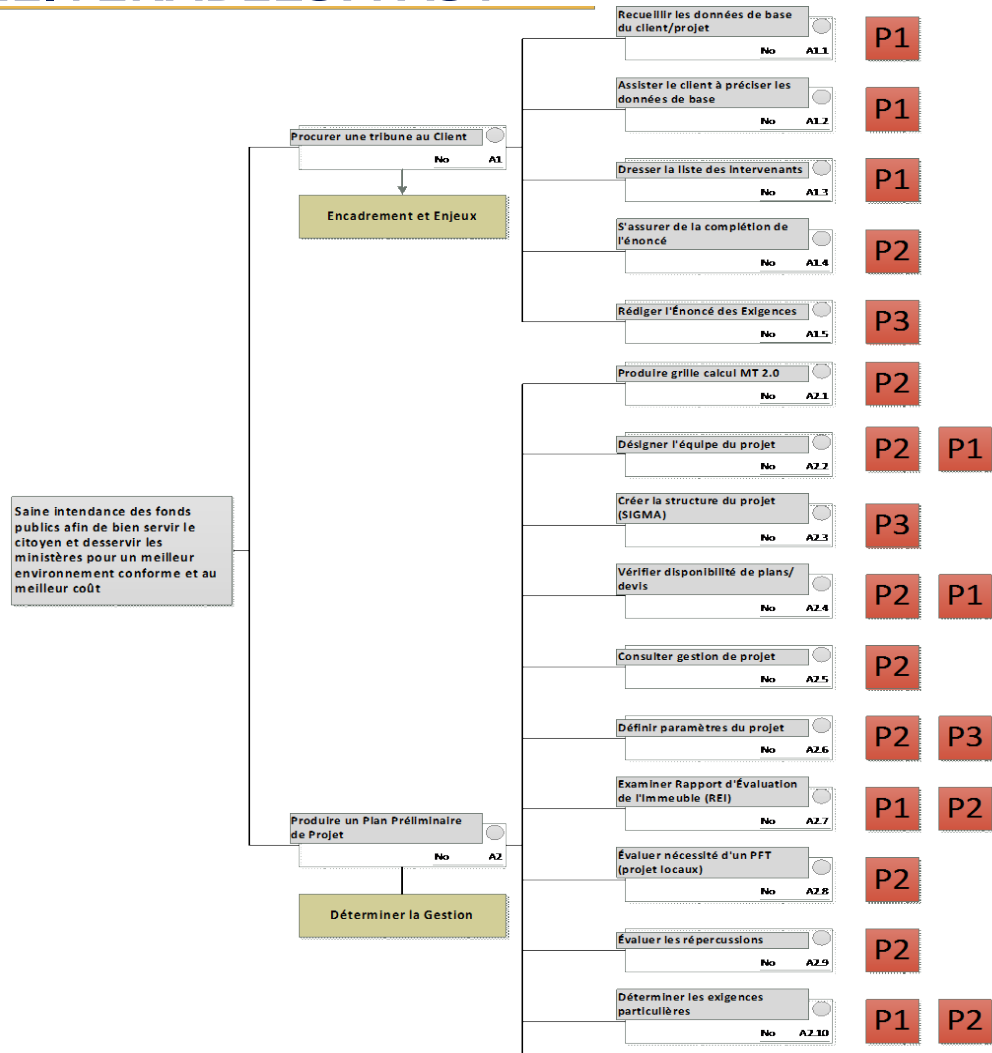



5. DELIVERABLES: CHARACTERIZATION

PROFIL	2 ANALYSE		
FONCTION		Analyser les données de projet	
CRITÈRES PHYSIOLOGIQUES	UNITÉ	NIVEAU	FLEX
acuité visuelle	pts	10 points à 600 mm	F0
confort thermique	oC	selon ASHRAE et standard SPAC	F1
confort acoustique	NC	45 dBA	F2
qualité de l'air	cA/hre	selon ASHRAE et standard SPAC	F1
humidité relative	%	selon ASHRAE et standard SPAC	F1
ergonomie	libre	selon normes SPAC	F0
CRITÈRES FONCTIONNELS	UNITÉ	NIVEAU	FLEX
facilité d'accès data	vitesse	10 sec/virtuel - 5 min/papier	F1
degré de concentration	VAR	variabilité normale / distractions permises	min
calme requis	NC	45 dBA	F2
communications	nature	interactions parlées de courtes durées	F0
		communications à distance : tel/web	F0
sécurité	vitesse évac	selon CNB	F0
échange data	vitesse	S/O	
CRITÈRES PSYCHOLOGIQUES	UNITÉ	NIVEAU	FLEX
personnalisation	estime	non requis	
intimité acoustique	STI	selon niveau de sécurité SPAC	F0
intimité visuelle	vues	confidentialité des données affichées selon SPAC	F0
confidentialité des communications	STI	selon niveau de sécurité SPAC	F0
perspectives	distance	distention des pupilles - 250 mètres	min
stimulation visuelle	estime	modérée - champs d'action limité	F2
stimulation auditive	estime	modérée - champs d'action limité	F2
stimulation olfactive	estime	modérée - champs d'action limité	F2
orientation dans l'espace	degré d'aide	position du poste identifiée sans aide/ wayfinding	F0
stimulation intellectuelle	estime	mineure - processus analytique en cours	max



5. DELIVERABLES: PROFILE

PROFIL 2 : ANALYSE

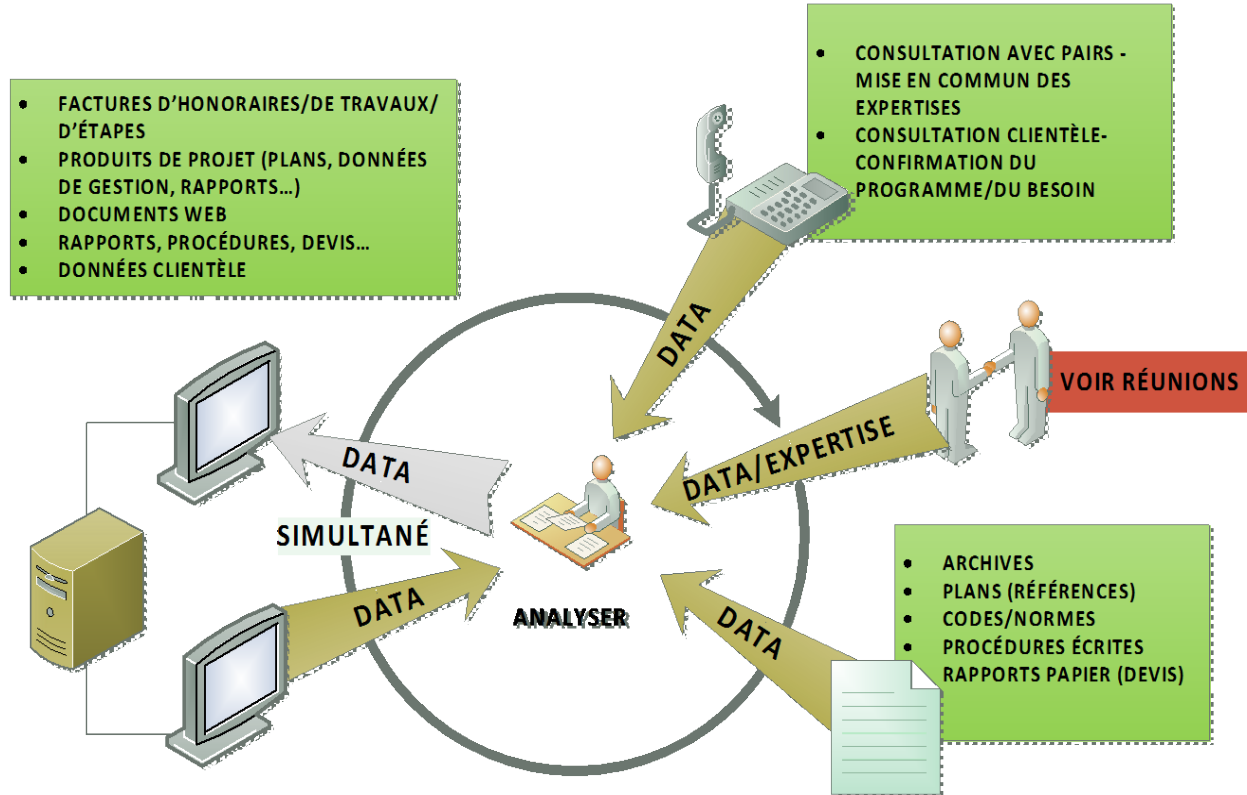



5. DELIVERABLES: DESIGN

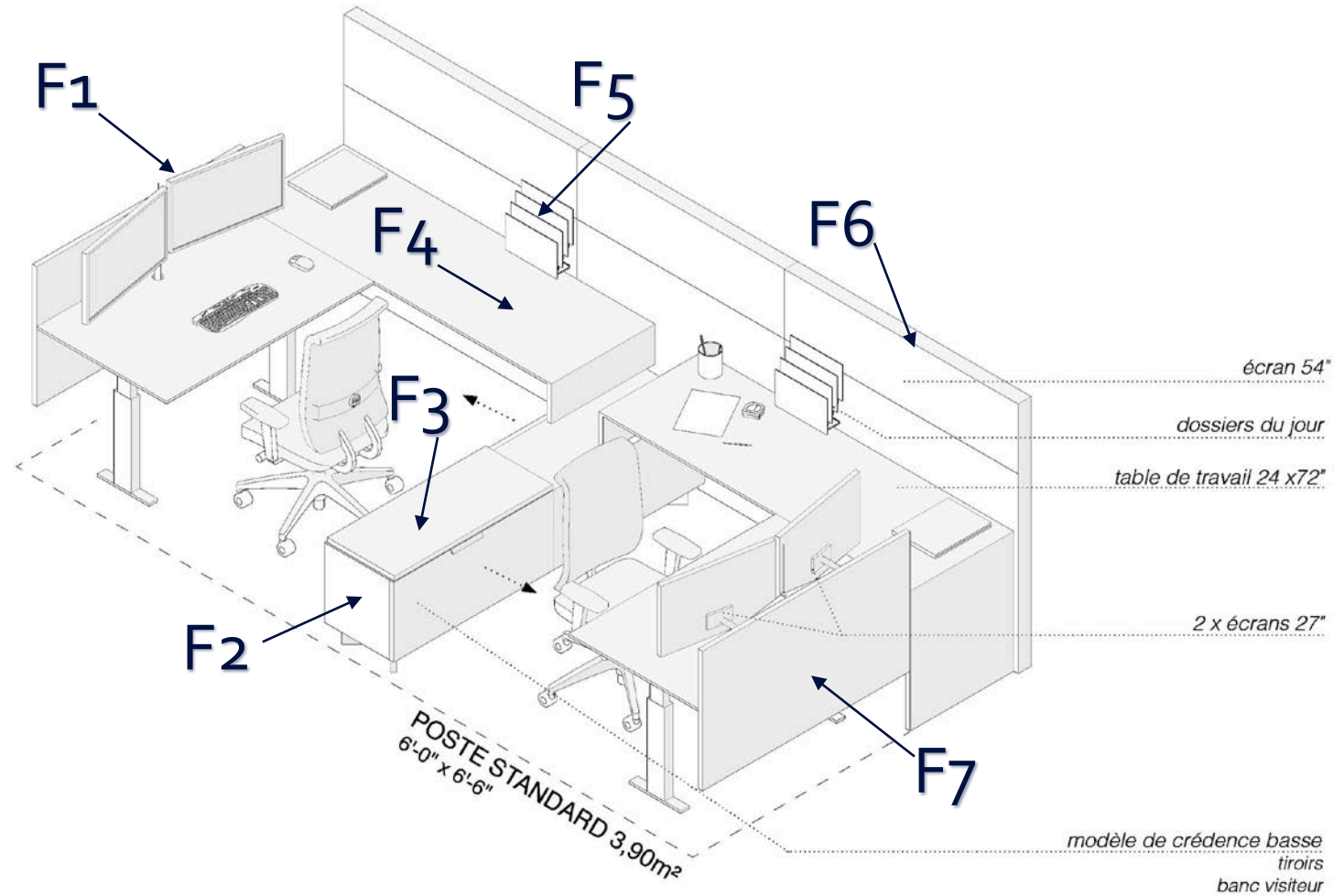



5. DELIVERABLES: DESIGN





6. COSTS



**Operational costs override construction costs.
A 3% increase in productivity doubles
the construction budget.**

13. QUESTION PERIOD

Thank you!

If you have further questions:

gil.goyette@videotron.ca



GIL GOYETTE, ARCHITECTURE CONSEIL